

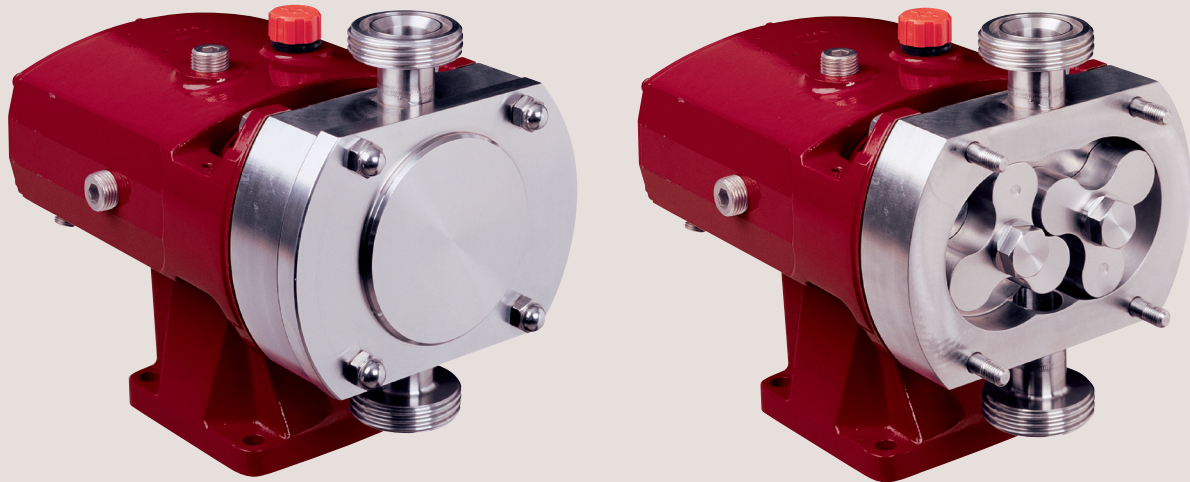

Series S

Rotary Lobe Pumps for all applications



SSP Series S stainless steel rotary lobe pumps operate at the heart of process industries worldwide. Series S pumps fulfil a wide range of application requirements throughout Chemical, Food, Pharmaceutical and other related industries.

Handling from low to high viscosity pumped media the characteristic smooth, low shear pumping action is ideal for delicate media and where organic solids in suspension, creams, froths, gels, emulsions and mixtures are to be pumped.

Series S pumps are suitable for CIP (Cleaning In Place), conform to USA 3A Sanitary Standard and are certified by EHEDG (European Hygienic Equipment Design Group) as fully CIP cleanable to their protocol.

User Benefits

- High efficiency
- Low energy consumption
- Compact size
- Robust construction
- Smooth flow
- Reversible operation
- Low shear pumping
- Minimal pumped media agitation
- Hygienic design
- Easy maintenance
- EHEDG accreditation
- ATEX compliance

Series S pumps are also classified for use in potentially explosive atmospheres under the ATEX Directive 94/9/EC Group II, Categories 2 & 3, with temperature classification T1 to T4.



Operation

The positive displacement of the Series S pump is provided by noncontacting, contra rotating tri-lobe or bi-lobe rotors within a fully swept pump chamber. All Series S pumps are capable of bi-rotational flow without modification.

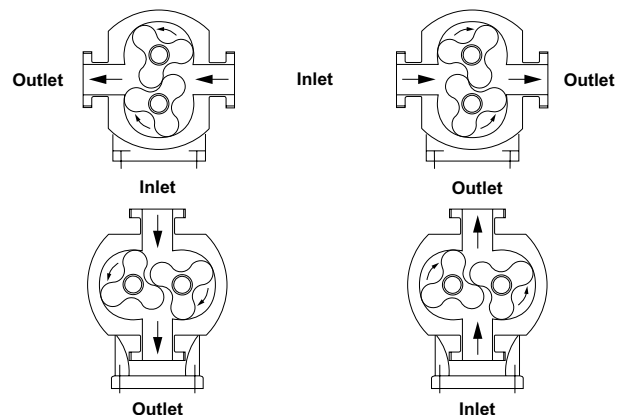

Performance

The Series S pump range has twelve pump head displacements ranging from 0.053 litres/rev to 3.53 litres/rev.

- Flow rates up to 106 m³/h
- Differential pressures up to 20 bar
- Port sizes from 25 mm to 150 mm diameter

High Volumetric Efficiency – The Series S pump offers high efficiency transfer of low, medium and high viscosity pumped media. This important aspect of performance is achieved by maintaining high accuracy and repeatability of component part manufacture, thereby maximising shaft rigidity and minimising the effects of thermal expansion within the pump gearbox. This combination allows the optimum pump head geometry to be achieved which, in turn, maximises volumetric efficiency.

Low NPSH – The Series S pump with standard port connections has full through-bore inlet and outlet ports to International Standards. This reduces inlet and outlet port losses, thereby lowering NPSH requirements.

Basic Design

The Series S pump with its modular design giving a choice of 44 models, provides for greater application flexibility and cost effective easy maintenance.

Pumphead – All metallic pumped media wetted components are manufactured in 316L type stainless steel. The Series S in standard specification has tri-lobe rotors available in three temperature ratings, allowing the pump to be operated at maximum temperatures of 70°C, 130°C and 200°C for both process and CIP.

Shafts – 316L Stainless steel shafts are used for pressures up to 10 bar. Higher pressures up to 20 bar are attained by the use of high strength duplex stainless steel.

Gearbox – The Series S pump has a robust cast iron gearbox with a universal design for models S1 to S4. This gives the flexibility of mounting pumps with the inlet and outlet ports in either a vertical or horizontal plane by changing the foot and its position. The Series S models S5 and S6 have a choice of two dedicated gearbox castings, which allows the inlet and outlet ports to be in either the vertical or horizontal plane.

Pump Model	Inlet and Outlet Connection size International standard		Displacement litres/rev	Differential Pressure bar	Maximum Speed rev/min	Weight Bare Shaft Pump	
	Standard Port mm	Enlarged Port mm				Horizontal Porting (H) kg	Vertical Porting (V) kg
S1-0005-*08	25	-	0.053	8	1000	15	16
S1-0008-*05	25	40	0.085	5	1000	17	18
S2-0013-*10	25	40	0.128	10	1000	28	30
S2-0013-*15	25	40	0.128	15	1000	28	30
S2-0018-*07	40	50	0.181	7	1000	29	31
S2-0018-*10	40	50	0.181	10	1000	29	31
S3-0027-*10	40	50	0.266	10	1000	53	56
S3-0027-*15	40	50	0.266	15	1000	53	56
S3-0038-*07	50	65	0.384	7	1000	56	59
S3-0038-*10	50	65	0.384	10	1000	56	59
S4-0055-*10	50	65	0.554	10	1000	105	111
S4-0055-*20	50	65	0.554	20	1000	105	111
S4-0079-*07	65	80	0.79	7	1000	110	116
S4-0079-*15	65	80	0.79	15	1000	110	116
S5-0116-*10	65	80	1.16	10	600	152	152
S5-0116-*20	65	80	1.16	20	600	152	152
S5-0168-*07	80	100	1.68	7	600	160	160
S5-0168-*15	80	100	1.68	15	600	160	160
S6-0260-*10	100	100	2.60	10	500	260	260
S6-0260-*20	100	100	2.60	20	500	260	260
S6-0353-*07	100	150	3.53	7	500	265	265
S6-0353-*15	100	150	3.53	15	500	265	265

* = H or V

H = Horizontal Porting

V = Vertical Porting

Specification Options



Pump overload protection

For essential overload protection to protect pump, drive unit and also limit pressure build up within associated process equipment, the pump can be fitted with a pressure relief valve.

This is supplied as an integral part of the pump, not requiring any external pipework. The design is such that the valve mechanism is isolated from the pumped media. Mechanical or pneumatic operation is available for both pressure/safety and cleaning bypass.

Surface finish and coatings

To enhance standard surface finish or for hygiene purposes, the pumphead and rotors may be electro polished. For abrasive applications the stainless steel pumphead and rotors may be supplied with a tungsten carbide coating or other surface hardening treatment to increase wear resistance.

Interchangeable rotors

Mathematically defined profile and precision manufacture ensure interchangeability of rotors with sealed involute splines giving accurate position, location and positive rotor drive.

Option of bi-lobe rotors in stainless steel for handling products containing large delicate solids, or bi-lobe rotors manufactured from non-galling alloy for increased efficiencies. Elastomeric tri-lobe rotors can also be offered where the application dictates.

Pumped media seals

The optimum primary seal can be chosen to match the pumped media and duty conditions. Single or double mechanical seals include flushed or aseptic variants. For arduous duties hard faced seal materials such as tungsten carbide or silicon carbide can be used. Packed glands offer a simple, low cost, and easy to maintain controlled leakage sealing arrangement.

Pumped media wetted elastomers are EPDM, NBR, FPM all FDA conforming or PTFE for chemical applications.

Heating / Cooling devices

These are primarily used for heating the pumphead so as to maintain the pumped media viscosity and reduce risk of any crystallisation/solidification. They may also be used for cooling purposes when required.

Connections

Comprehensive choice covering

- Screwed male connections to all major standards including BSP, DIN11851, ISS/IDF, NPT, Rdg, RJT, SMS, Tri-clamp and more.
- Flange connections to all major standards including ASA/ANSI150, BS4504/DIN2533, BS10E and more.
- Enlarged diameter and rectangular ports for handling very high viscosity products.

Motorised pump units

Pumps may be supplied fully motorised with fixed or variable speed drives including appropriate control systems if required, mounted on either mild or stainless steel baseplates.

In addition to electric motor drives, hydraulic, pneumatic, diesel or petrol powered prime movers can be fitted.

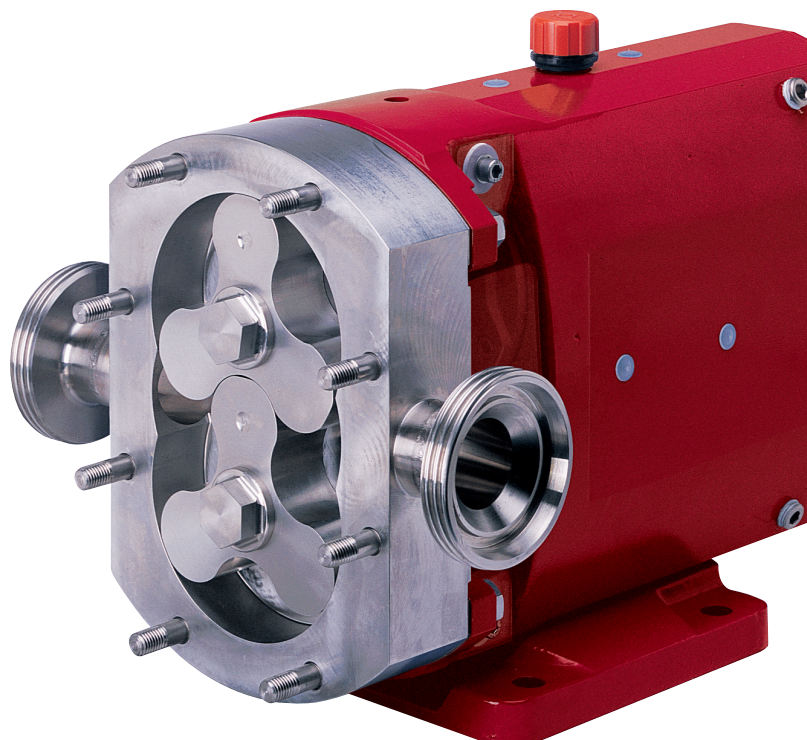

Bareshaft Pump Dimensions

Vertically ported

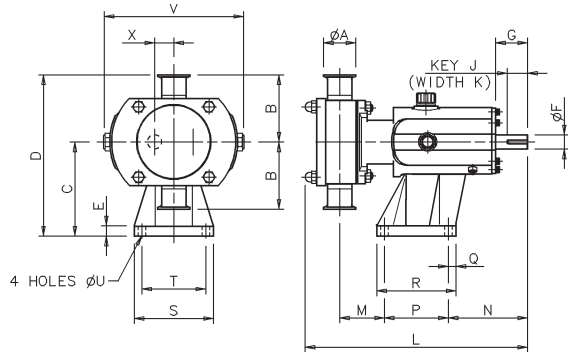

Horizontally ported

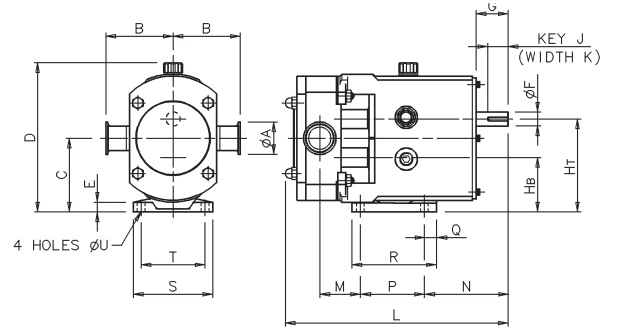

Vertically ported

All dimensions in mm

Pump Model	A1	A2	B	C	D	E	F	G	J	K	L	M	N	P	Q	R	S	T	U	V	X
S1-0005-V08	25	-	95	113	208	15	16	40	30	5	285	49	117	80	22	114	104	80	10	179	22.5
S1-0008-V05	25	40	95	113	208	15	16	40	30	5	295	55	117	80	22	114	104	80	10	179	22.5
S2-0013-V10 or V15	25	40	105	147	252	15	22	50	32	6	339	67	124	100	12	124	124	100	12	219	30
S2-0018-V07 or V10	40	50	105	147	252	15	22	50	32	6	348	70	124	100	12	124	124	100	12	219	30
S3-0027-V10 or V15	40	50	125	175	300	22	28	61	40	8	437	67.5	161	155	15	185	155	125	14	253	37.5
S3-0038-V07 or V10	50	65	125	175	300	22	28	61	40	8	450	72	161	155	15	185	155	125	14	253	37.5
S4-0055-V10 or V20	50	65	150	213	363	25	38	80	63	10	541	78	197	200	17	234	184	150	14	307	48
S4-0079-V07 or V15	65	80	150	213	363	25	38	80	63	10	558	87	197	200	17	234	184	150	14	307	48
S5-0116-V10 or V20	65	80	175	256.5	431.5	30	45	110	70	14	627	91.5	264	200	20	240	220	180	14	345	60
S5-0168-V07 or V15	80	100	175	256.5	431.5	30	45	110	70	14	650	103	264	200	20	240	220	180	14	345	60
S6-0260-V10 or V20	100	100	190	295	485	30	48	110	70	14	748	124	267	260	20	300	250	210	14	400	70
S6-0353-V07 or V15	100	150	190	295	485	30	48	110	70	14	777	139	267	260	20	300	250	210	14	400	70

A1: Standard Port

A2: Enlarged Port

Horizontally ported

All dimensions in mm

Pump Model	A1	A2	B	C	D	E	F	G	HB	HT	J	K	L	M	N	P	Q	R	S	T	U
S1-0005-H08	25	-	95	90.5	189	10	16	40	68	113	30	5	285	42	124	80	10	100	100	80	10
S1-0008-H05	25	40	95	90.5	189	10	16	40	68	113	30	5	295	48	124	80	10	100	100	80	10
S2-0013-H10 or H15	25	40	105	115	233	15	22	50	85	145	32	6	339	60	131	100	19	132	124	100	12
S2-0018-H07 or H10	40	50	105	115	233	15	22	50	85	145	32	6	348	63	131	100	19	132	124	100	12
S3-0027-H10 or H15	40	50	125	137.5	273	18	28	61	100	175	40	8	437	82.5	176	125	30	181	154	125	14
S3-0038-H07 or H10	50	65	125	137.5	273	18	28	61	100	175	40	8	450	87	176	125	30	181	154	125	14
S4-0055-H10 or H20	50	65	150	163	325	20	38	80	115	211	63	10	541	101	224	150	35	202	184	150	14
S4-0079-H07 or H15	65	80	150	163	325	20	38	80	115	211	63	10	558	110	224	150	35	202	184	150	14
S5-0116-H10 or H20	65	80	175	195	376	20	45	110	135	255	70	14	627	97	279	180	35	275	210	180	14
S5-0168-H07 or H15	80	100	175	195	376	20	45	110	135	255	70	14	650	108	279	180	35	275	210	180	14
S6-0260-H10 or H20	100	100	190	225	429	20	48	110	155	295	70	14	748	124.5	266	260	40	370	220	190	14
S6-0353-H07 or H15	100	150	190	225	429	20	48	110	155	295	70	14	777	140	266	260	40	370	220	190	14

A1: Standard Port

A2: Enlarged Port

P/101/1001

The information contained herein is correct at the time of issue, but may be subject to change without prior notice.